



POLAR CASCADE™

Unit Specifications

COOLING TOWER

PC-060

SP-PC-060

Nominal tons are based on 95°F HW,
85°F CW, 78° Wet Bulb and 3GPM/Ton

GPM:	180
Electrical:	208-230/460/3
Fans:	1 - 42"
Blades:	4
Motors:	1 - 2 hp
RPM:	1725
Full Load Amps:	208: 7.0 230: 5.8 460: 2.9
Cabinet:	16 GA. Galvannealed Steel
Base:	12 GA. Galvannealed Steel
Hot Water Basin:	16 GA. Stainless Steel
Finish:	3 mil. "Polane" Coating

Nominal Tons: 60

Depth:	87.781"
Width:	72.200"
Height:	73.512"

Water Inlet:	6"
Water Outlet:	6"
Overflow:	2"
Make-up Water:	3/4"

Cold Water Basin Capacity:	63.64 gal.
Hot Water Basin Capacity:	66.83 gal.

Shipping Weight:	1,010 lbs.
Operating Weight:	3,591 lbs.

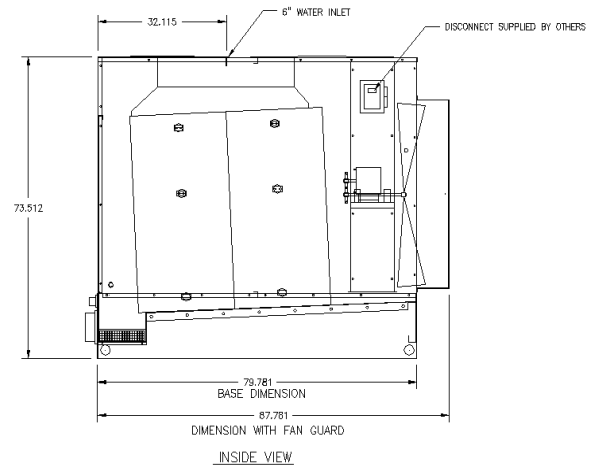
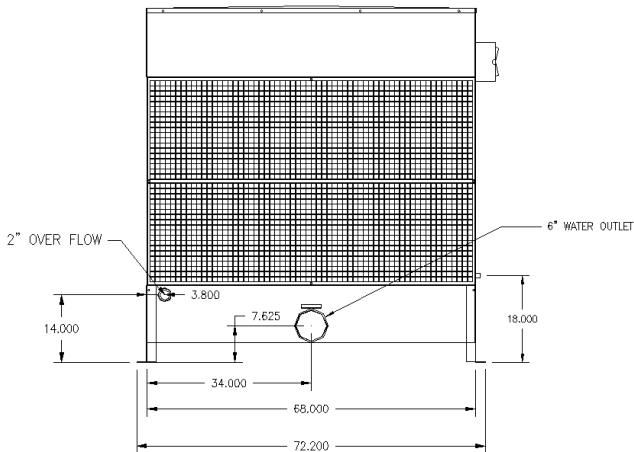

Available Accessories

- Water Storage Tank
- Intake Air Filter
- Basin Heater
- Heater Control Panel
- Vibration Isolators

*Cascade Cooling Towers are completely assembled. No field assembly required.
All units are run tested prior to shipment.*

Polar Air Systems, LLC

St. Louis, MO

www.polarairsystems.com

636-300-1589

© 2007 Polar Air Systems, LLC

SS-PC-060-708SS-PC-060-708