



**POLAR CASCADE™**

# Unit Specifications

**COOLING TOWER**

**PC-005**

**SP-PC-005**

Nominal tons are based on 95°F HW,  
85°F CW, 78° Wet Bulb and 3GPM/Ton

GPM:	15
Electrical:	208-230/1
Fans:	1 - 24"
Blades:	4
Motors:	1 - 1/2 hp
RPM:	825
Full Load Amps:	208: 2.7 230: 3.7

Cabinet:	16 GA. Galvannealed Steel
Base:	12 GA. Galvannealed Steel
Hot Water Basin:	16 GA. Stainless Steel
Finish:	3 mil. "Polane" Coating

## Nominal Tons: 5

Depth:	50.155"
Width:	36.000"
Height:	57.182"
Water Inlet:	4"
Water Outlet:	2"
Overflow:	2"
Make-up Water:	3/4"

Cold Water Basin Capacity:	25.79 gal.
Hot Water Basin Capacity:	11.00 gal.

Shipping Weight:	380 lbs.
Operating Weight:	714 lbs.

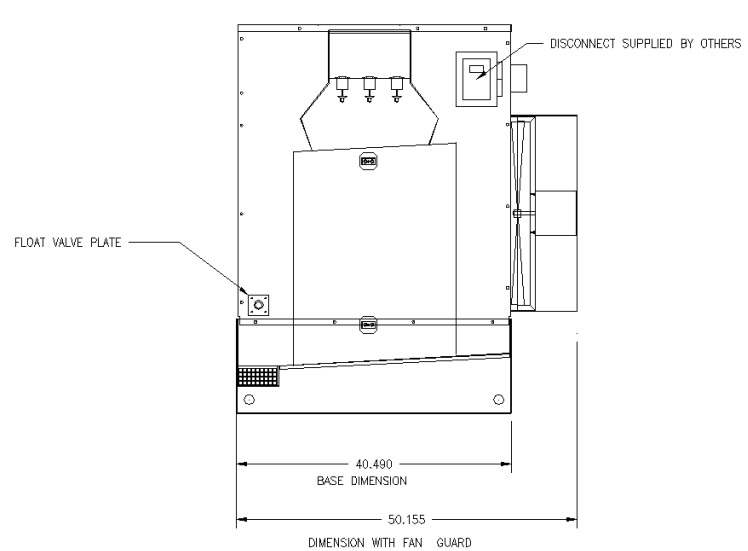
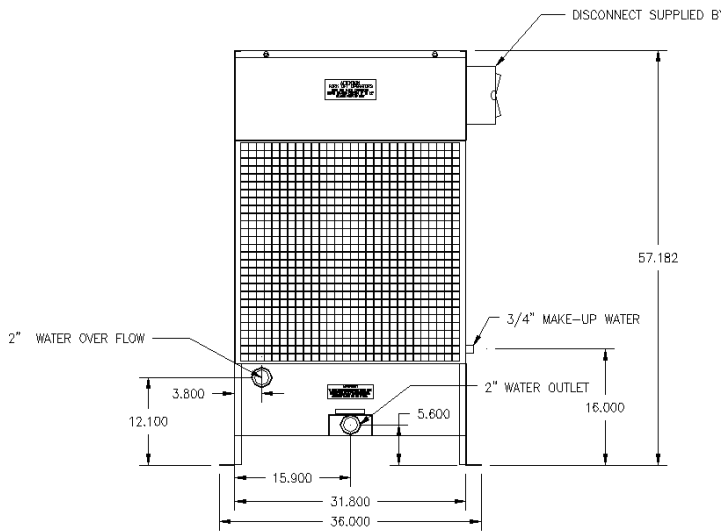

### Available Accessories

- Water Storage Tank
- Intake Air Filter
- Basin Heater
- Heater Control Panel
- Vibration Isolators

*Cascade Cooling Towers are completely assembled. No field assembly required.  
All units are run tested prior to shipment.*

## Polar Air Systems, LLC

St. Louis, MO

[www.polarairsystems.com](http://www.polarairsystems.com)

636-300-1589

© 2007 Polar Air Systems, LLC