

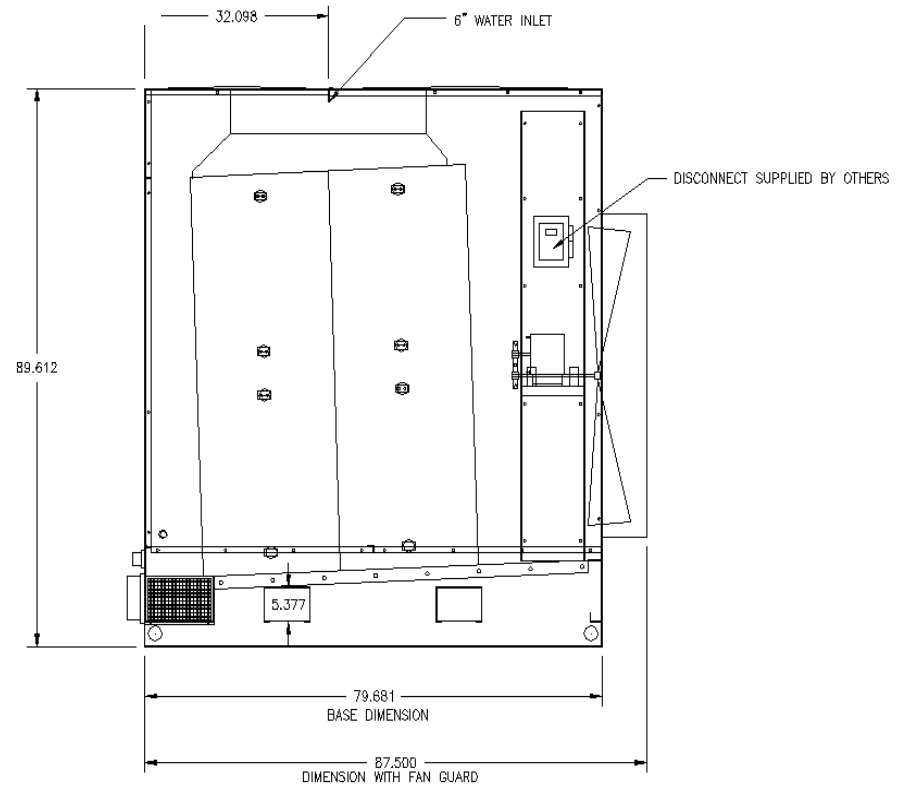

Notes

1. MATERIAL: SPRAY NOZZLE ASSEMBLY, MEDIA CHANNEL & DRAIN SCREEN: 16GA 304 STAINLESS STEEL
2. MATERIAL: CABINET 16GA GALVANEAELED STEEL OR 304 STAINLESS STEEL UNLESS NOTED OTHERWISE
3. MATERIAL: BASE: 12GA GALVANEAELED STEEL OR 304 STAINLESS STEEL UNLESS NOTED OTHERWISE
4. FINISH: POLANE COATING OR STAINLESS STEEL 2B MILL FINISH
5. ALL GALVANEAELED STEEL TO BE ASTM A653 A40 AND/OR A60

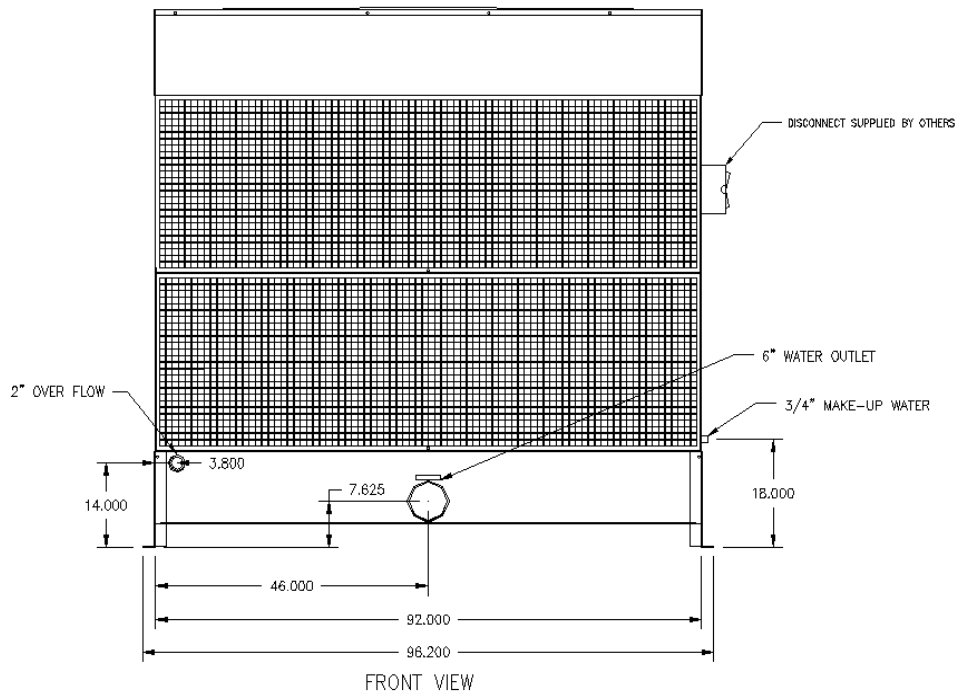

Electrical: 208-230/460/3
 Fans: [1] 54"
 Motors: [1] 3 hp
 Full Load Amps: 10.8-8.4/4.2

**THIS DRAWING IS THE PROPERTY OF POLAR AIR SYSTEMS, LLC
 ANY USE WITHOUT WRITTEN PERMISSION IS PROHIBITED**

© Polar Air Systems, LLC, 2008

Polar Air Systems, LLC		
	Do Not Scale	Revision
Date: July 1, 2008	Drawing	1
TITLE	PC-110 Detail	Drawing No:
		PC-F-110-708
Product: POLAR CASCADE COOLING TOWER		