

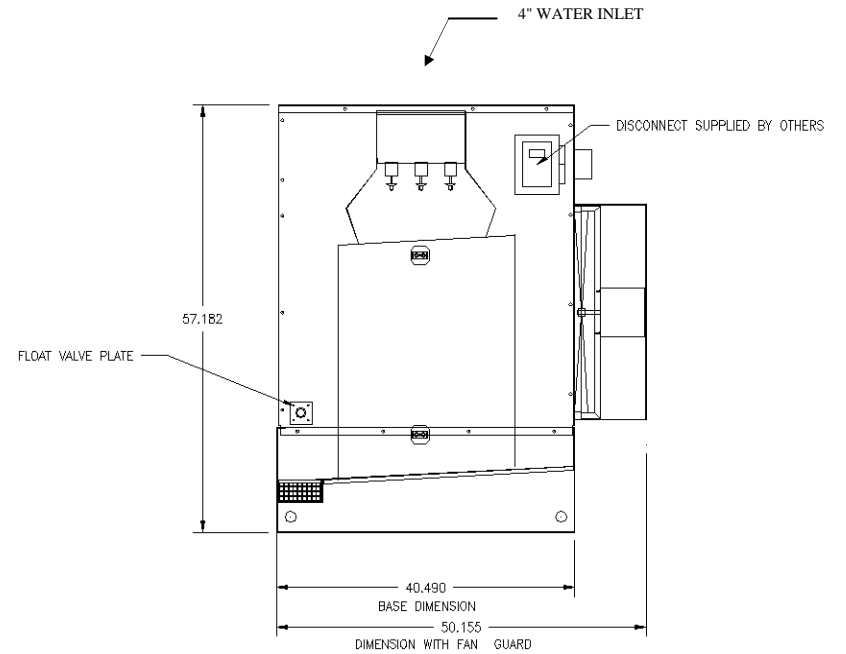

Notes

1. MATERIAL: SPRAY NOZZLE ASSEMBLY, MEDIA CHANNEL & DRAIN SCREEN: 16GA 304 STAINLESS STEEL
2. MATERIAL: CABINET 16GA GALVANEALD STEEL OR 304 STAINLESS STEEL UNLESS NOTED OTHERWISE
3. MATERIAL: BASE: 12GA GALVANEALD STEEL OR 304 STAINLESS STEEL UNLESS NOTED OTHERWISE
4. FINISH: POLANE COATING OR STAINLESS STEEL 2B MILL FINISH
5. ALL GALVANEALD STEEL TO BE ASTM A653 A40 AND/OR A60

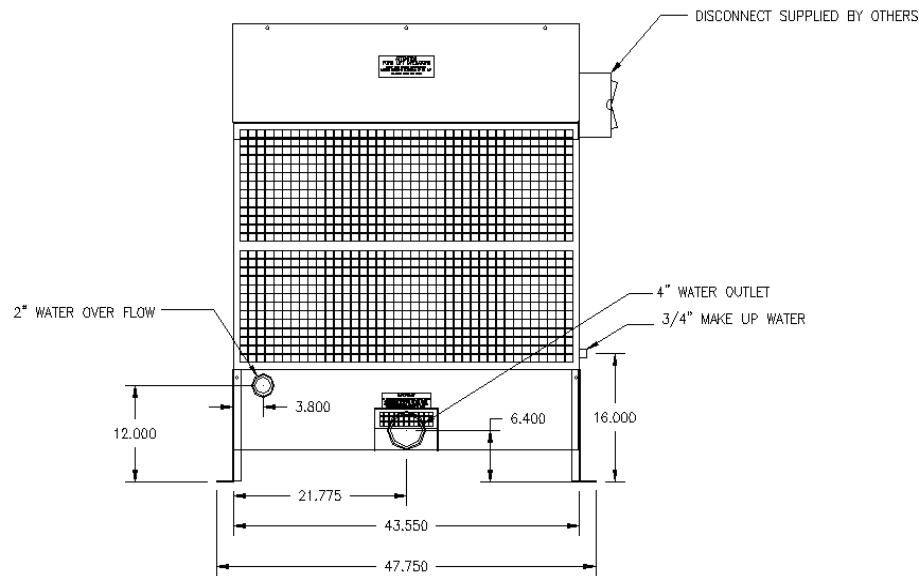

Electrical: 208-230/1
 Fans: [1] 24"
 Motors: [1] 3/4 hp
 Full Load Amps: 4.2 to 5.2

**THIS DRAWING IS THE PROPERTY OF POLAR AIR SYSTEMS, LLC
 ANY USE WITHOUT WRITTEN PERMISSION IS PROHIBITED
 © Polar Air Systems, LLC, 2008**

Polar Air Systems, LLC		
	Do Not Scale	Revision
Date: July 1, 2008	Drawing	1
TITLE	PC-020 Detail	Drawing No: PC-B-020-708
Product: POLAR CASCADE COOLING TOWER		